

## Step-6

Variant	Item No.	Description
19830	STEP-6-BLK	4W Die-cast Aluminium, Recessed Wall Light - 3000K Warm White. Black Finish
19831	STEP-6-BLK	4W Die-cast Aluminium, Recessed Wall Light - 5000K White. Black Finish
19474	STEP-6-SLR	4W Die-cast Aluminium, Recessed Wall Light - 3000K Warm White. Aluminium Finish
19475	STEP-6-SLR	4W Die-cast Aluminium, Recessed Wall Light - 5000K White. Aluminium Finish
19832	STEP-6-WHT	4W Die-cast Aluminium, Recessed Wall Light - 3000K Warm White. White Finish
19833	STEP-6-WHT	4W Die-cast Aluminium, Recessed Wall Light - 5000K White. White Finish

Thank you for purchasing your new LED Step-Wide. Please take the time to read and understand the instruction sheet below. Failure to do so may void warranty.

## Specifications

Voltage:	240V	Lumen (±5%):	Warm White 3000K - 500lm White 5000K - 550lm	Dimmable:	No
Power:	4W	CCT:	3000K - 5000K	CRI:	≥85
IP Rating:	65	Lifespan:	40,000hrs		

## Steps:

- Please make a visual inspection of the fixture prior to installation. If any defects are to be found please return to your place of purchase for a replacement.
- All electrical work is to be carried out by a qualified and licenced electrician.
- Please determine the method of installation. Internal cavity wall or exterior hollow/solid wall.
- If installation is for internal the polycarbonate housing is not required. Please carefully measure before cutting and hole.
- If the installation is used outside it's recommended that the polycarbonate housing is used. This will offer the correct mounting size to suit the fixture.
- Before any installation make sure all electrical power is correctly turned off from the mains and NOT just from the light switch.
- Remove the screws using the supplied Allen key. Once the base plate is removed please insure the silicon gasket is still attached to the base. If not carefully place the gasket into the allocated position.
- Proceed in connecting the power wire to the supplied terminal block. Please ensure wires are correctly tightened. Due to the nature of this fitting the earth wire MUST be connected. Please note the supplied grommet/s must not be removed from the fixture. Removing and not using will void warranty.
- It's recommended a round type flex is used to ensure penetration through the cable glands on the rear of the fixture. If this is NOT used the responsibility is placed on the installer to ensure correct and adequate IP rating.
- Once connection has been made to proceed in attaching the fixture to the base plate. Carefully tighten screws with equal tension. Please do not over tighten as the screws may strip.
- Once happy with the installation please turn the mains power back and test for any defects.
- To keep the finish maintained and in good appearance the manufacture recommends cleaning the fixture once every 12 months depending on environmental conditions. Please use fresh clean water and a mild soap. Rinse well.

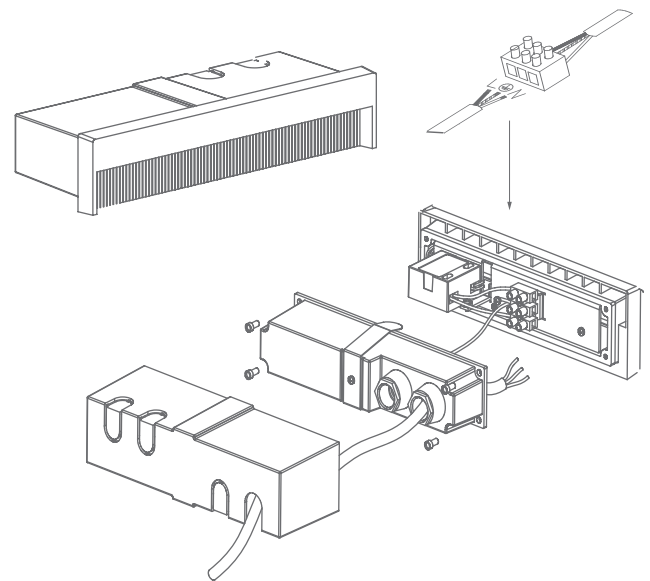

**Note:** -The lamp must be installed by professional electrician  
-Ensure the power supply is switched off before fitting this product

-Do not touch the lamp when in use  
-Keep away from hot steam and corrosive gas